

WINDLOAD CHARTS

A = 15 P.S.F. D = 30 P.S.F.
 B = 20 P.S.F. E = 40 P.S.F.
 C = 25 P.S.F. F = 60 P.S.F.

CG451 SERIES

DESCRIPTION: 2" x 4 1/2" CENTER GLAZED SYSTEM
 CATEGORY: STOREFRONT
 SCALE: NTS

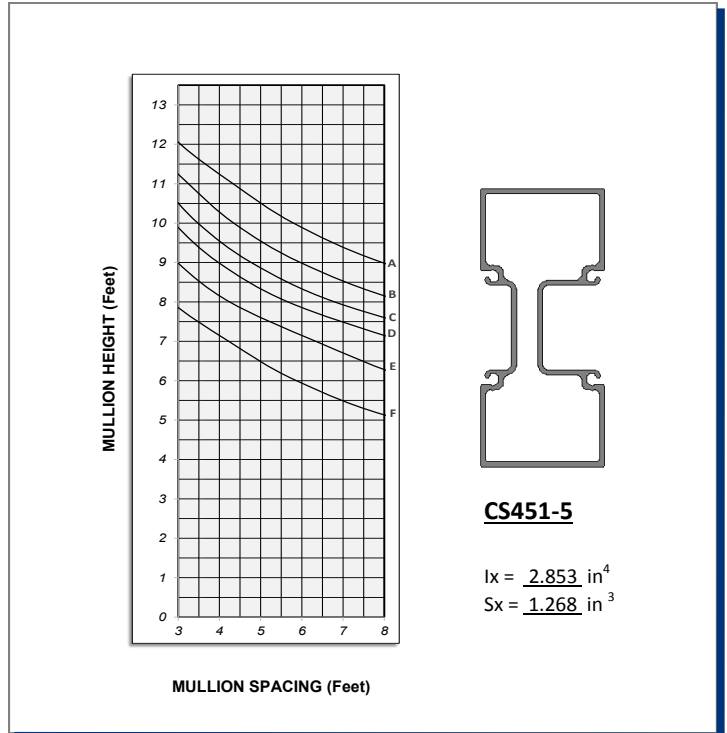
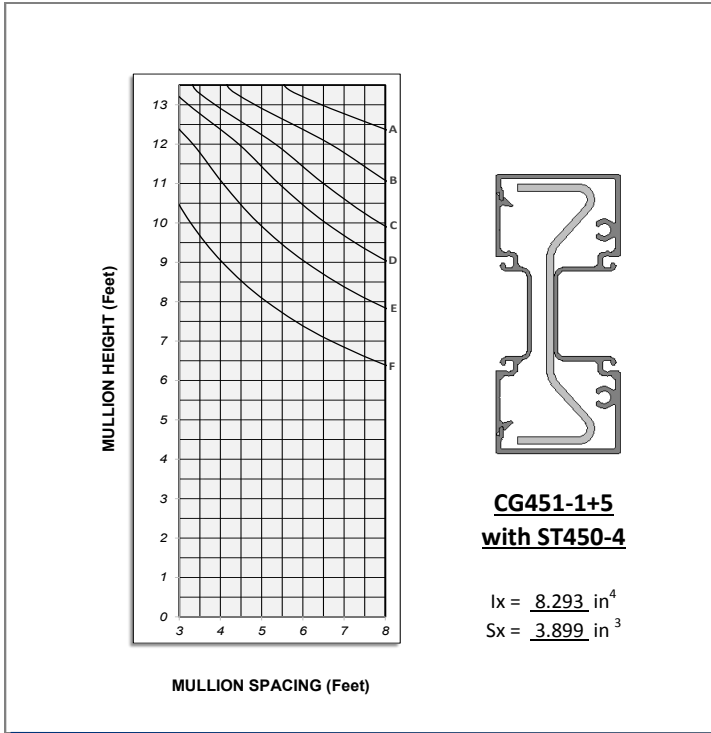
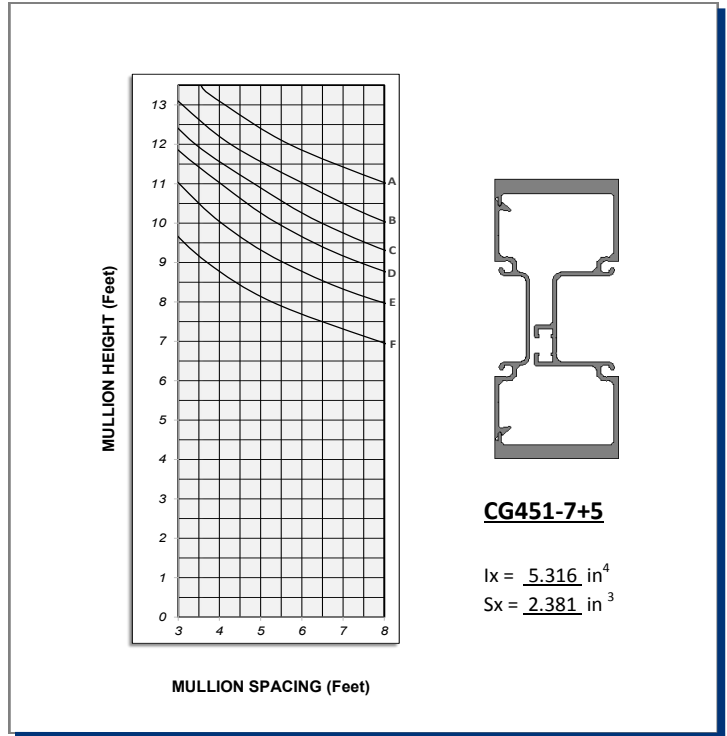
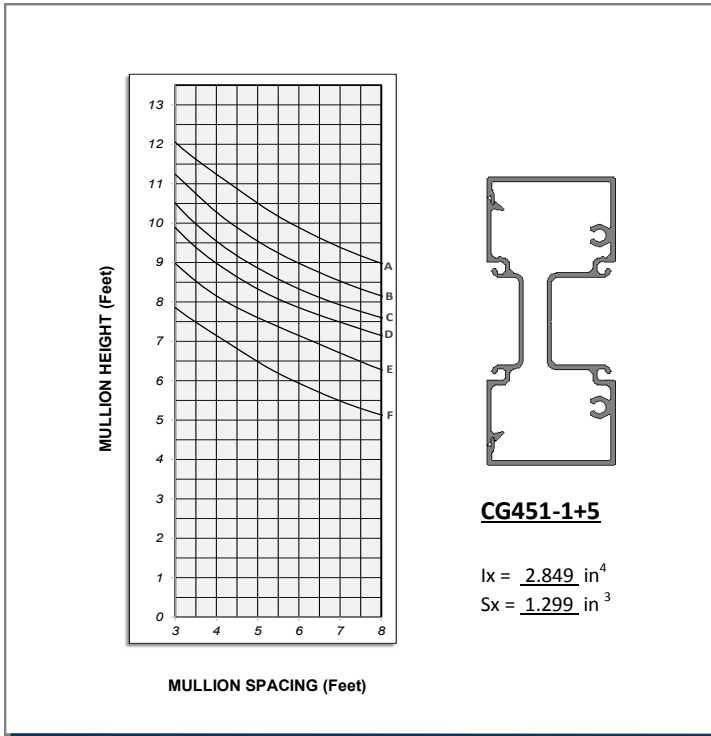

RELEASE 01.2015

TRULITE GLASS & ALUMINUM SOLUTIONS | www.trulite.com | 800.432.8132

- ◆ Deflections have been calculated using the algebraic sum of the individual I_x -values.
- ◆ Bending stress has been apportioned by relative I_x of the appropriate members.
- ◆ Mullions are assumed to be a single span, simple beam, uniformly loaded and adequately braced against lateral-torsional buckling. All other complex design conditions shall be reviewed by a design professional.
- ◆ Aluminum extrusions shall be 6063-T6 ($F_y=25\text{ksi}$) alloy. Steel reinforcement if used shall be A36 steel ($F_y=36\text{ksi}$) minimum. Allowable stresses to be derived as per Table 2-21 of Aluminum Design Manual, 2010. Deflection limitation of mullions shall be in accordance with AAMA TIR-A11 of $L/175$ or $3/4"$ (which ever is less) for spans up to 13'-6" and $L/240 + 1/4$ for all others where L is equal to the span of mullion.
- ◆ For mullions containing steel reinforcement, the reinforcement is assumed to be installed for the full length of the mullion. A design professional shall be consulted for instances where steel reinforcement is installed for a partial length of the mullion span.
- ◆ Windload pressure determinations shall be as per the 2012 IBC and ASCE 7-10 (nominal/ASD) and according to local governing codes. A professional engineer shall be consulted for the most current laws and local building codes.
- ◆ Selection of perimeter fasteners and attachment of glazing system to the building structure are project specific and therefore shall be reviewed and determined by a design professional.
- ◆ Trulite assumes no responsibility for selecting the appropriate systems for specific projects.



WINDLOAD CHARTS

A = 15 P.S.F. D = 30 P.S.F.
 B = 20 P.S.F. E = 40 P.S.F.
 C = 25 P.S.F. F = 60 P.S.F.

CG451 SERIES

DESCRIPTION: 2" x 4 1/2" CENTER GLAZED SYSTEM
 CATEGORY: STOREFRONT
 SCALE: NTS

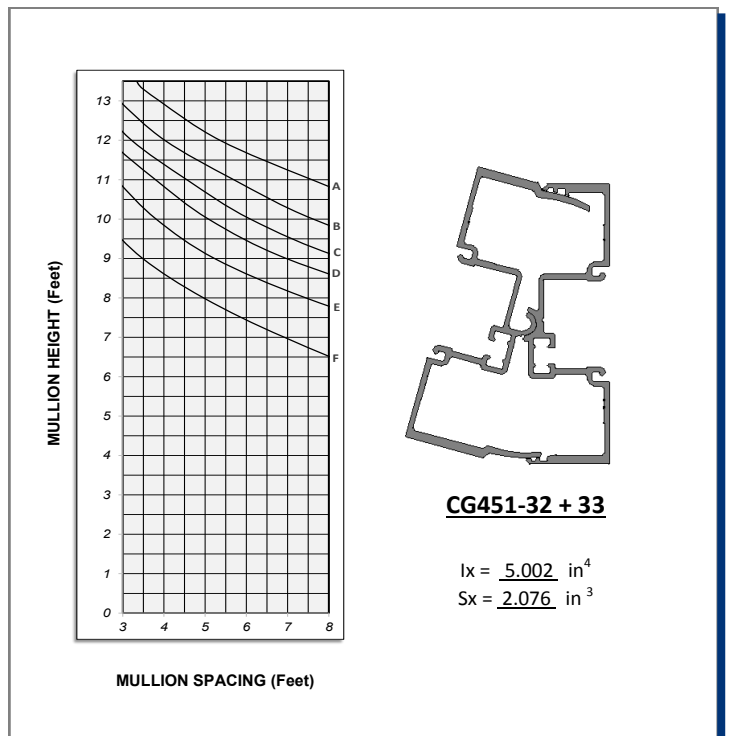
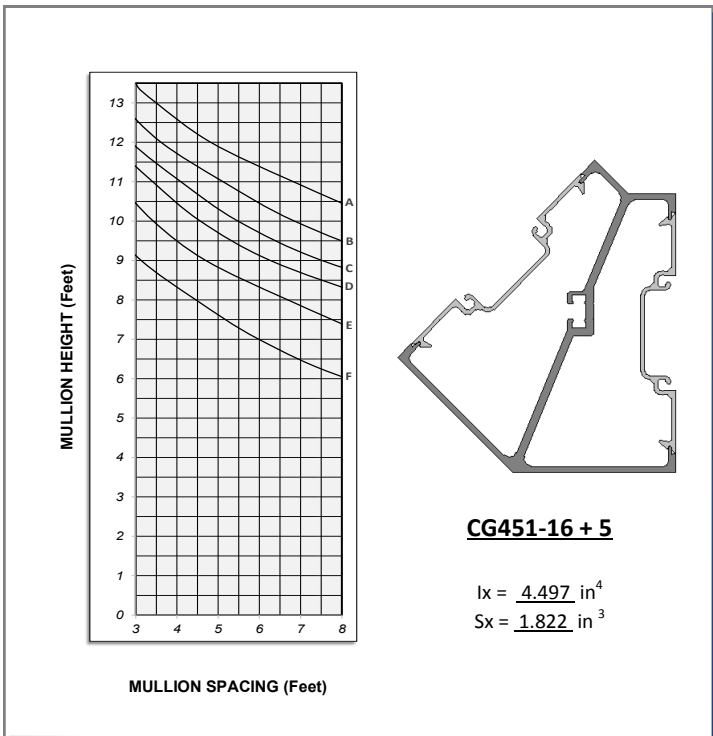
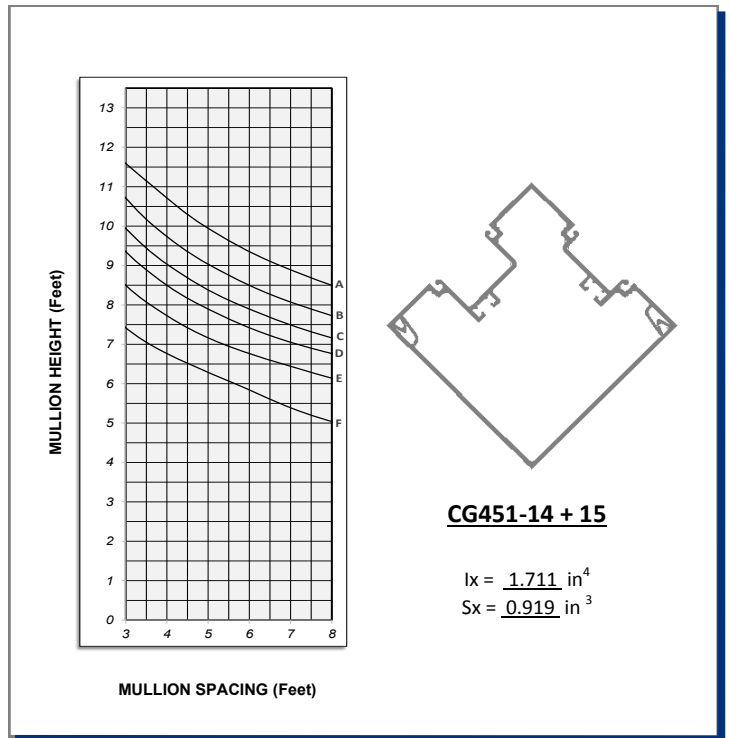
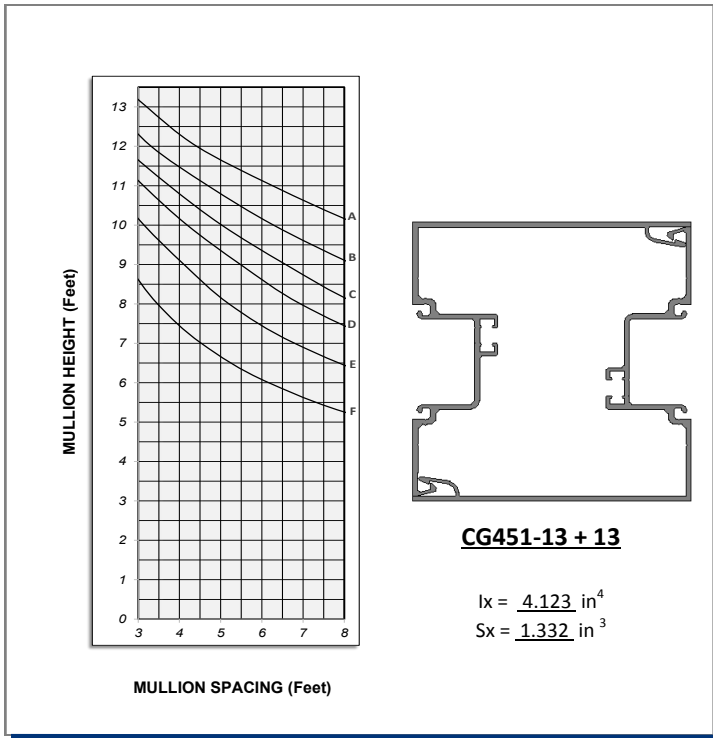

RELEASE 01.2015

TRULITE GLASS & ALUMINUM SOLUTIONS | www.trulite.com | 800.432.8132

- ◆ Deflections have been calculated using the algebraic sum of the individual I_x -values.
- ◆ Bending stress has been apportioned by relative I_x of the appropriate members.
- ◆ Mullions are assumed to be a single span, simple beam, uniformly loaded and adequately braced against lateral-torsional buckling. All other complex design conditions shall be reviewed by a design professional.
- ◆ Aluminum extrusions shall be 6063-T6 ($F_y=25\text{ksi}$) alloy. Steel reinforcement if used shall be A36 steel ($F_y=36\text{ksi}$) minimum. Allowable stresses to be derived as per Table 2-21 of Aluminum Design Manual, 2010. Deflection limitation of mullions shall be in accordance with AAMA TIR-A11 of $L/175$ or $3/4"$ (which ever is less) for spans up to 13'-6" and $L/240 + 1/4$ for all others where L is equal to the span of mullion.
- ◆ For mullions containing steel reinforcement, the reinforcement is assumed to be installed for the full length of the mullion. A design professional shall be consulted for instances where steel reinforcement is installed for a partial length of the mullion span.
- ◆ Windload pressure determinations shall be as per the 2012 IBC and ASCE 7-10 (nominal/ASD) and according to local governing codes. A professional engineer shall be consulted for the most current laws and local building codes.
- ◆ Selection of perimeter fasteners and attachment of glazing system to the building structure are project specific and therefore shall be reviewed and determined by a design professional.
- ◆ Trulite assumes no responsibility for selecting the appropriate systems for specific projects.



WINDLOAD CHARTS

A = 15 P.S.F. D = 30 P.S.F.
 B = 20 P.S.F. E = 40 P.S.F.
 C = 25 P.S.F. F = 60 P.S.F.

CG451 SERIES

DESCRIPTION: 2" x 4 1/2" CENTER GLAZED SYSTEM
 CATEGORY: STOREFRONT
 SCALE: NTS

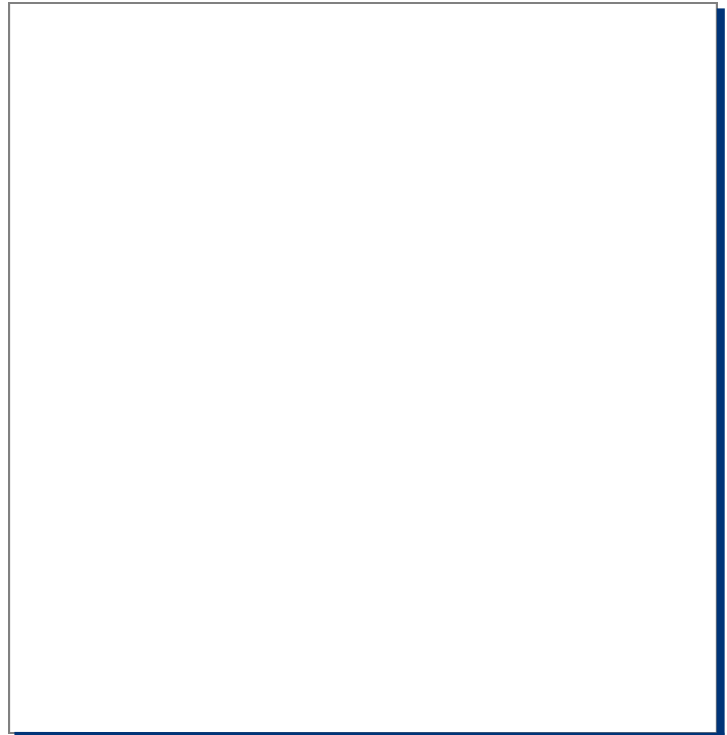
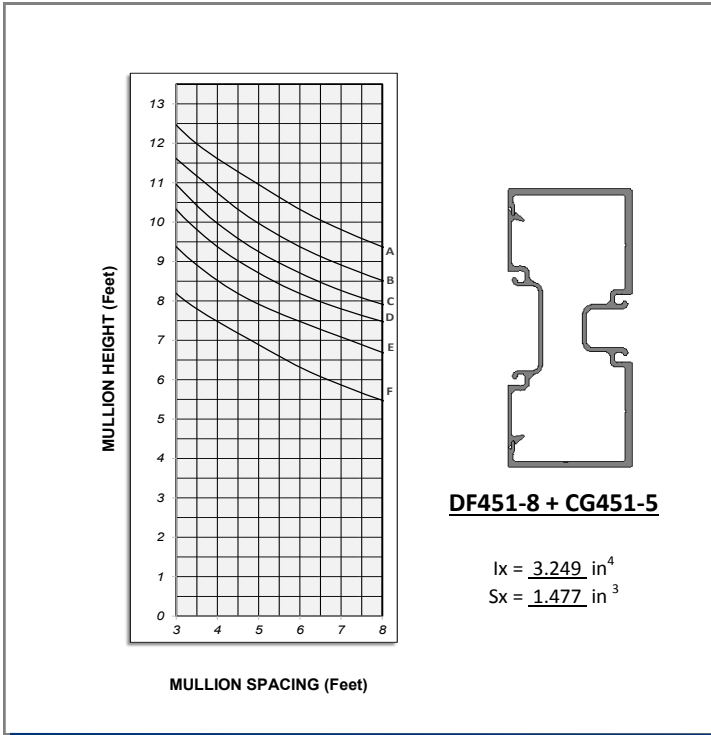
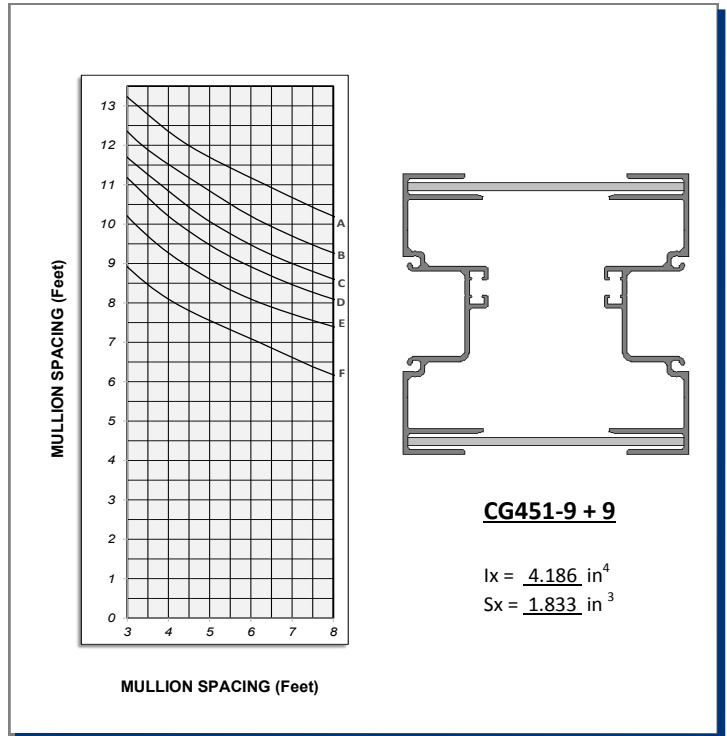
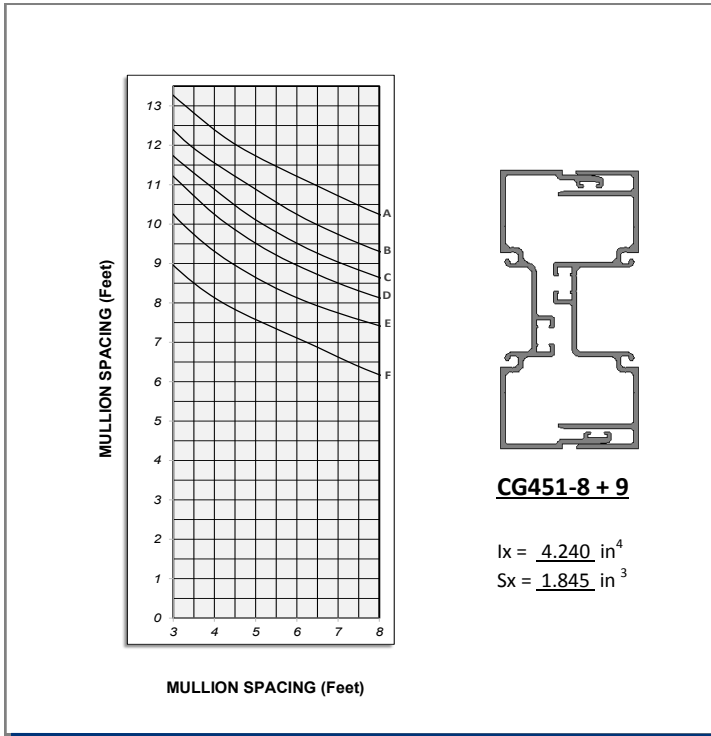

RELEASE 01.2015

TRULITE GLASS & ALUMINUM SOLUTIONS | www.trulite.com | 800.432.8132

- ◆ Deflections have been calculated using the algebraic sum of the individual I_x -values.
- ◆ Bending stress has been apportioned by relative I_x of the appropriate members.
- ◆ Mullions are assumed to be a single span, simple beam, uniformly loaded and adequately braced against lateral-torsional buckling. All other complex design conditions shall be reviewed by a design professional.
- ◆ Aluminum extrusions shall be 6063-T6 ($F_y=25\text{ksi}$) alloy. Steel reinforcement if used shall be A36 steel ($F_y=36\text{ksi}$) minimum. Allowable stresses to be derived as per Table 2-21 of Aluminum Design Manual, 2010. Deflection limitation of mullions shall be in accordance with AAMA TIR-A11 of $L/175$ or $3/4"$ (which ever is less) for spans up to $13'-6"$ and $L/240 + 1/4$ for all others where L is equal to the span of mullion.
- ◆ For mullions containing steel reinforcement, the reinforcement is assumed to be installed for the full length of the mullion. A design professional shall be consulted for instances where steel reinforcement is installed for a partial length of the mullion span.
- ◆ Windload pressure determinations shall be as per the 2012 IBC and ASCE 7-10 (nominal/ASD) and according to local governing codes. A professional engineer shall be consulted for the most current laws and local building codes.
- ◆ Selection of perimeter fasteners and attachment of glazing system to the building structure are project specific and therefore shall be reviewed and determined by a design professional.
- ◆ Trulite assumes no responsibility for selecting the appropriate systems for specific projects.



DEADLOAD CHARTS

A = 1/4 Point Loading
B = 1/8 Point Loading

CG451 SERIES

DESCRIPTION: 2" x 4 1/2" CENTER GLAZED SYSTEM
CATEGORY: STOREFRONT
SCALE: NTS

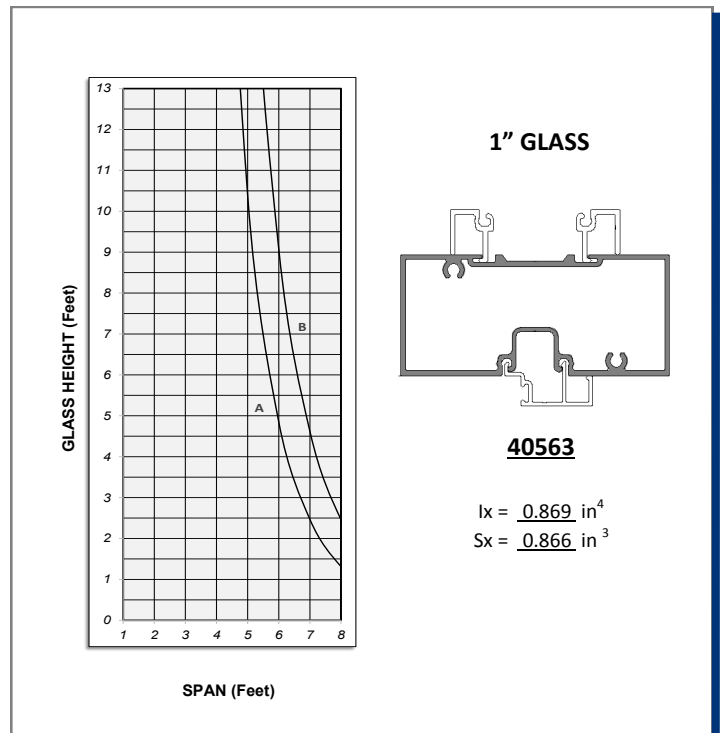
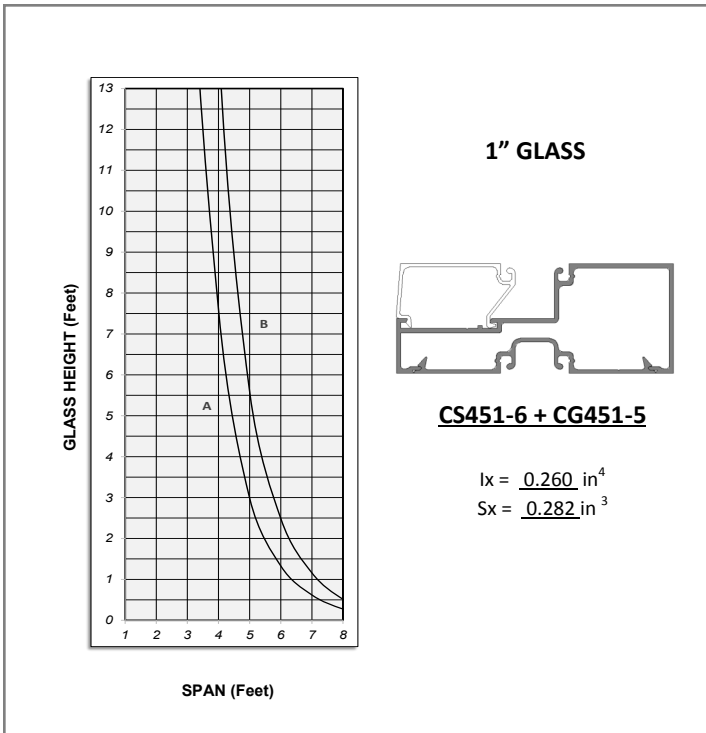
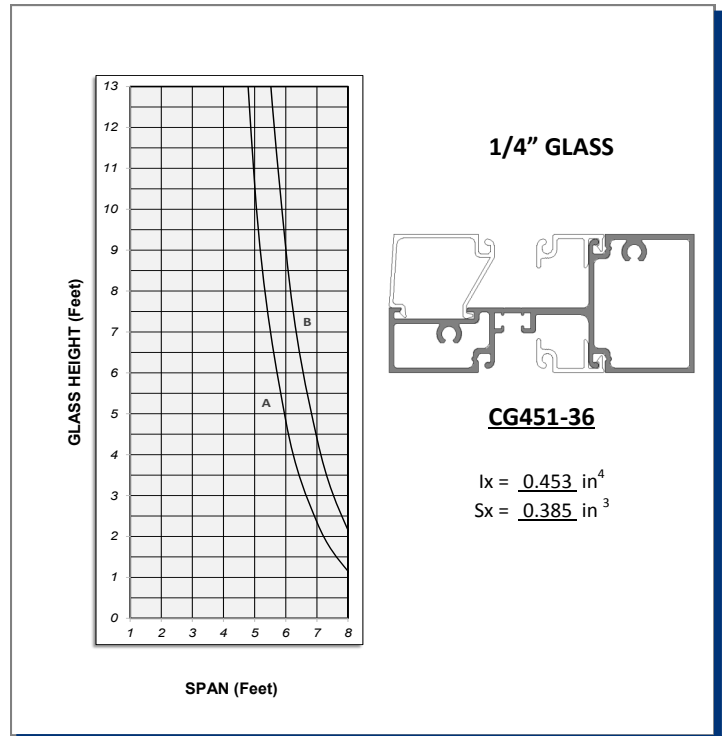
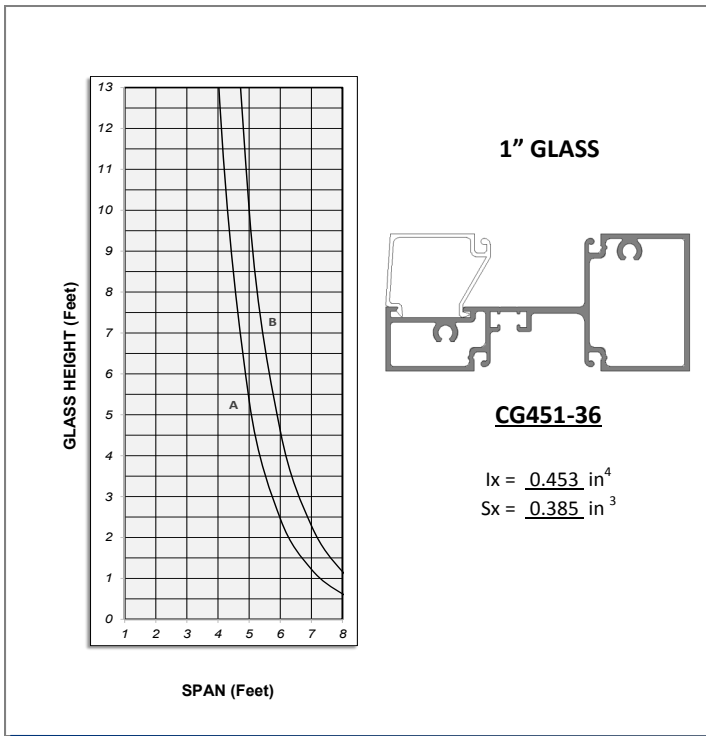

RELEASE 01.2015

TRULITE GLASS & ALUMINUM SOLUTIONS | www.trulite.com | 800.432.8132

- ◆ Deflections have been calculated using the algebraic sum of the individual I_x -values.
- ◆ Bending stress has been apportioned by relative I_x of the appropriate members.
- ◆ Transoms are assumed to be single span and glass deadload is concentrated at $L/4$ or $L/8$, where L is equal to the span of transom.
- ◆ Aluminum extrusions shall be 6063-T6 ($F_y=25\text{ksi}$) alloy. Steel reinforcement if used shall be A36 steel ($F_y=36\text{ksi}$) minimum. Allowable stresses to be derived as per Table 2-21 of Aluminum Design Manual, 2010. Deflection limitation of transoms shall be $L/360$ as per IBC 2012 Sect. 1604.3 or $1/8"$ (whichever is less).
- ◆ For transoms containing steel reinforcement, the reinforcement is assumed to be installed for the full length of the transom. A design professional shall be consulted for instances where steel reinforcement is installed for a partial length of the transom span.
- ◆ Deadload considered is based on $1/4"$ thick or $1"$ (actual total glass thickness = $0.5"$) thick glass and weight of transom member plus reinforcement if any.
- ◆ Selection of perimeter fasteners and attachment of glazing system to the building structure are project specific and therefore shall be reviewed and determined by a design professional.
- ◆ Trulite assumes no responsibility for selecting the appropriate systems for specific projects.

